

ATMOSPHERIC SEAL
20 CPM



GAS FLUSH
14 CPM



HERMETIC SHRINK
20 CPM



GT1s

Automatic, large-capacity, high speed, in-line tray sealing system designed to cut labour costs.

It combines high throughput with rapid tool-changing and space-saving compact design

Optional 'free-flow' gas flush Modified Atmosphere Packaging (MAP) available for extended shelf life.

Capable of up to 80 Atmospheric packs per minute with a 4 impression tool, the **GT1s** system is packed with user-friendly benefits including our unique Promotion modular conveyor system.

Designed to accept randomly spaced trays from any conveyor and can be fully integrated with other line equipment.

Packaging Materials

Trays

- C-PET
- A-PET
- R-PET
- Polypropylene
- PVC / Styrene
- Board / Paper
- Smooth Wall Foil

Lidding

- Co-extruded and Laminated Polyester Films
- Foil
- Board
- Paper

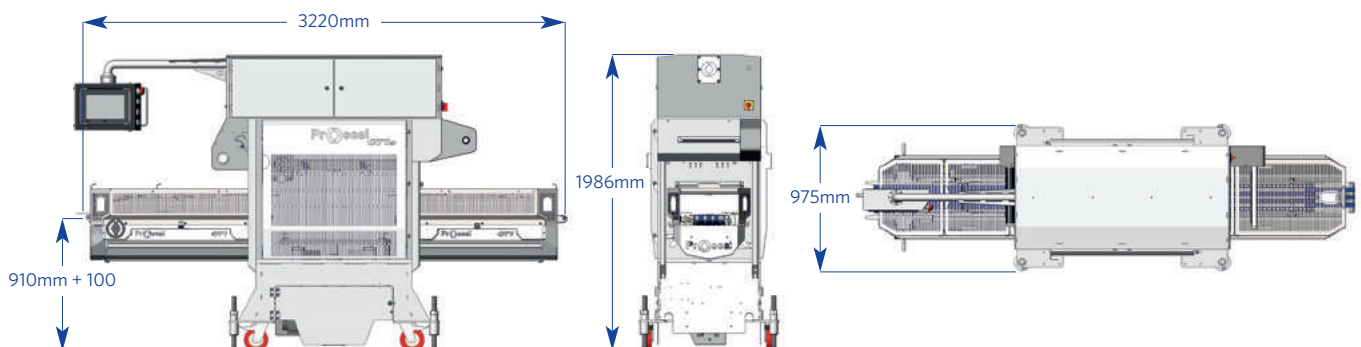

Standard design features and benefits

- Two minute tool changeover
- Low maintenance polymer bearings
- Simple and accurate film-feed system with easy film route
- Maintenance friendly robust construction
- Accurate temperature and seal pressure control
- High accuracy tool alignment system provides a constantly accurate sealing and/or film-cutting relationship with the tray flange profile
- Simple design and operation
- Film snap detection
- 'Auto Tool' Touch of a button tool change system, automatically locates and connects tooling to machine functions including all MAP options
- All around seal and contoured film-cut with skeletal film rewind
- Automatic seal operation with accurate seal dwell time
- Self-centring tray guides
- Automatic film roll clamping
- Food industry approved hygienic construction and wash-down protection
- Full Category 3 guarding
- User friendly, menu-driven control panel with step-by-step prompts, error and status displays, and useful batch pack counter
- Recipe handling of machine settings
- Self diagnostic system
- Pendant mounted colour touch screen HMI control for full double-sided operation
- Recipe driven auto machine set-up for tool change
- On-screen data capture and trends with wireless connection option
- Pot crush avoidance system
- Active film tension
- Integration of peripheral equipment, such as: infeed and outfeed conveyors, checkweighers, metal detectors and printers
- **QR Conveyors** with quick release belts for easy hygiene and maintenance
- **Eseal®** - high-performance, high-precision, high-force, energy-efficient, electric seal system that boasts a massive increase in seal force
- **Promotion** - a high accuracy continuous motion tray infeed system, which increases production speed whilst reducing machine duty

GT1s Specifications

Height	1986mm
Standard Length	3220mm
Width	975mm
Weight	1100kg
Electrical Supply	400V 3 phase + neutral (fused at 16A)
Transformer Variations	208V 3 phase (fused at 30A) 480V 3 phase (fused at 20A) 600V 3 phase (fused at 15A)

Metric

Pressure	Flow	Pressure	Flow
6 Bar	50L/Min	87psi	1.7CFM

Imperial

Transformers are available to accommodate the electrical supplies in different countries

Options available

- Free flow gas flush MAP (Modified Atmosphere Packaging)
- High Oxygen (O²) gas flush
- Close Cut - Method of maximising throughput and reducing film waste
- Inboard Cut (IC) Option to provide 'form, fill and seal' tray presentation
- Film coding and printing
- Foil crimping
- Active conveyors to allow the machine to be used as a straight through conveyor when packs don't require sealing
- Back-to-back machine configurations
- Optional integration of peripheral equipment, such as: denesters, fillers, multi-head weighers, laser coders, labellers
- **eWON** - a machine connection system to deliver real time data and error condition support, remote setup, and software upgrades, using a customer's existing IT network
- **I-film** - intelligent film reel monitoring system which actively adjusts film tension based on reel diameter to increase print quality and film reel efficiency, reduce component duty, and provides a film end warning system
- **Protect** - a contactless machine login and audit trail system
- Sale, Lease Purchase and Rental options available

GT1s Sealing capacity

No. of trays	Length	Width	Depth	Diameter
One	300mm	670mm	105mm	270mm
Two	300mm	331mm	105mm	270mm
Three	300mm	212mm	105mm	212mm
Four	300mm	129mm	105mm	129mm
Five	300mm	98mm	105mm	98mm



FISH | BOARD



RED MEAT | C-PET



SNACK FOOD | A-PET



PRODUCE | A-PET



READY MEAL | C-PET

for more information UK +44 (0) 1625 856 600 America +1 804 447 9038 Australia +61 (0) 3 9397 0955

www.proseal.com

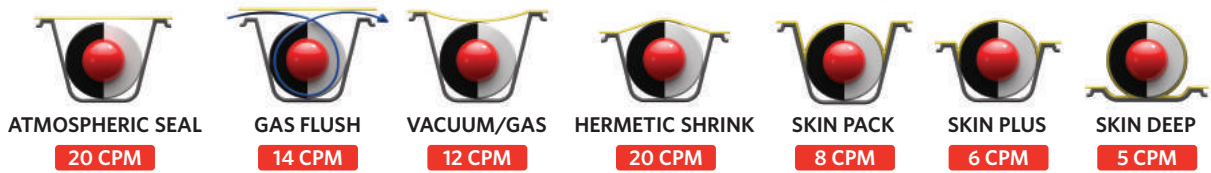
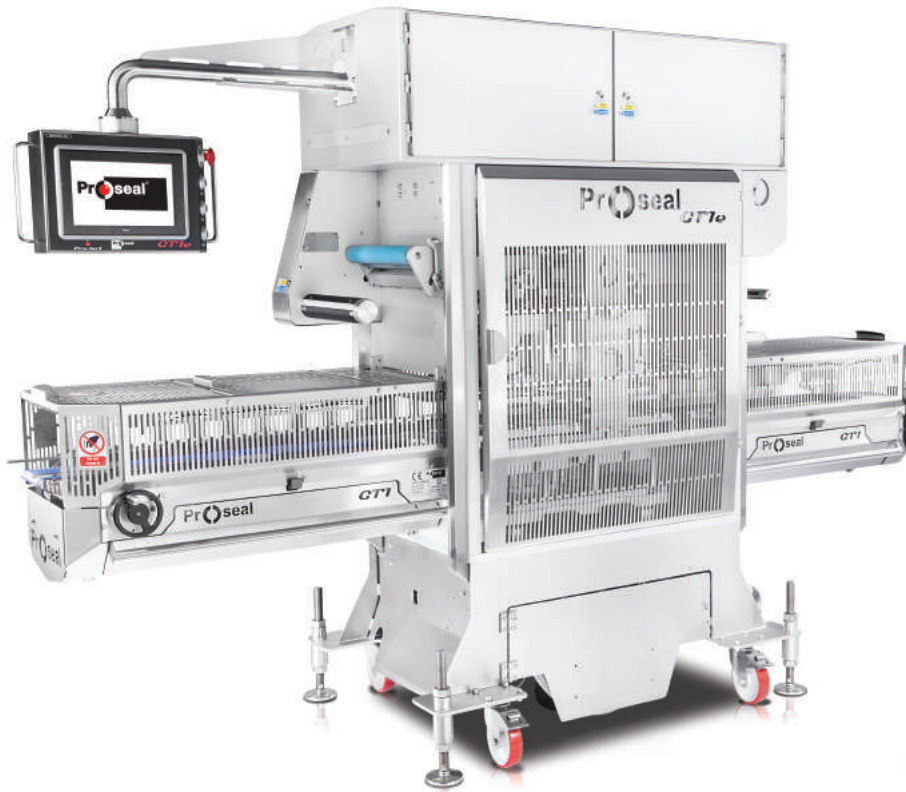

GT1e

Automatic, large-capacity, high-speed, in-line tray sealing system with full vacuum facility designed to cut labour costs.

At the core of the 'e' design is its flexibility to perform any style of heat seal to a pre-formed tray, be that atmospheric, MAP, VMAP, Skin, Skin Plus, or Skin Deep. Each of these options can be added now or at a later date, or indeed removed as necessary. This flexibility provides the user with the assurance that whatever the latest packaging trend might be, they have equipment suitably geared for the future.

Capable of producing up to 60 Vacuum/Gas packs per minute with a 5 impression tool, the GT1e system is packed with user-friendly benefits including our unique Promotion modular conveyor system.

Designed to accept randomly spaced trays from any conveyor and can be fully integrated with other line equipment.

Packaging Materials

Trays

- C-PET
- A-PET
- R-PET
- Polypropylene
- PVC / Styrene
- Board / Paper
- Smooth Wall Foil

Lidding

- Co-extruded and Laminated Polyester Films
- Foil
- Board
- Paper

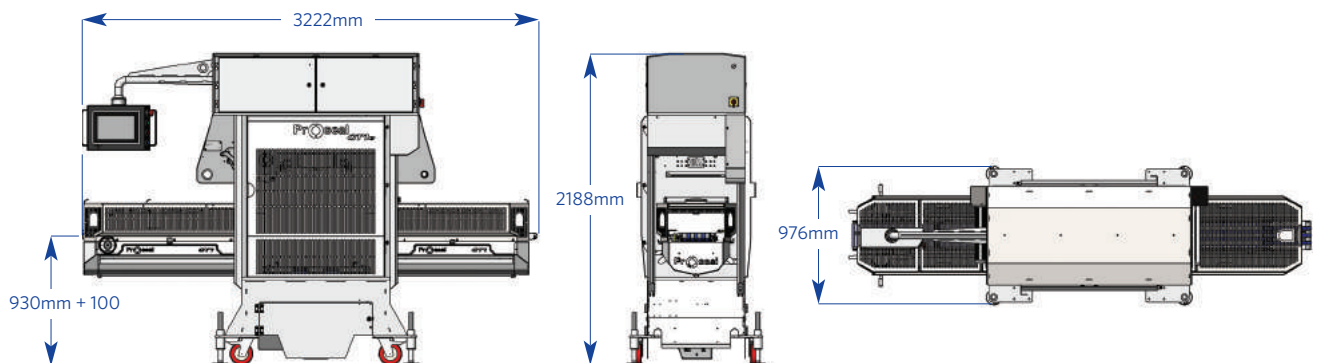

Standard design features and benefits

- Five minute tool changeover
- Low maintenance polymer bearings
- Simple and accurate film-feed system with easy film route
- Maintenance friendly robust construction
- Accurate temperature and seal pressure control
- High accuracy tool alignment system provides a constantly accurate sealing and/or film-cutting relationship with the tray flange profile
- Simple design and operation
- Film snap detection
- 'Auto Tool' Touch of a button tool change system, automatically locates and connects tooling to machine functions including all MAP options
- Integration of peripheral equipment, such as: infeed and outfeed conveyors, checkweighers, metal detectors and printers.
- All around seal and contoured film-cut with skeletal film rewind
- Automatic seal operation with accurate seal dwell time
- Self-centring tray guides
- Automatic film roll clamping
- Food industry approved hygienic construction and wash-down protection
- Full Category 3 guarding
- User friendly, menu-driven control panel with step-by-step prompts, error and status displays, and useful batch pack counter
- Recipe handling of machine settings
- Self diagnostic system
- Pendant mounted colour touch screen HMI control for full double-sided operation
- Recipe driven auto machine set-up for tool change
- On-screen data capture and trends with wireless connection option
- Pot crush avoidance system
- Active film tension
- **QR Conveyors** with quick release belts for easy hygiene and maintenance
- **Eseal®** - high-performance, high-precision, high-force, energy-efficient, electric seal system that boasts a massive increase in seal force
- **Promotion** - a high accuracy continuous motion tray infeed system, which increases production speed whilst reducing machine duty

GT1e Specifications

Height	2188mm
Standard Length	3222mm
Width	976mm
Weight	1350kg
Electrical Supply	400V 3 phase + neutral (fused at 16A)
Transformer Variations	208V 3 phase (fused at 30A) 480V 3 phase (fused at 20A) 600V 3 phase (fused at 15A)

Metric Imperial

Pressure	Flow	Pressure	Flow
6 Bar	50L/Min	87psi	1.7CFM
Required Supply for Skin Machine - (SD spec)			
6 Bar	707L/Min	87psi	25CFM

Transformers are available to accommodate the electrical supplies in different countries



SNACK FOOD | A-PET



FISH | SMOOTH WALL FOIL



POULTRY | POLYPROP



PRODUCE | A-PET



SNACK FOOD | A-PET

Options available

- Free flow gas flush MAP (Modified Atmosphere Packaging)
- High Oxygen (O²) gas flush
- Vacuum - used for applications such as retorting or for when the lid level needs to be controlled
- Vacuum Gas - ideal for where residual gas levels have to be sub 1%
- Skin - Skin packaging sub flange
- Skin Plus - Skin packaging up to 50mm above the tray flange
- Skin Deep - Skin packaging up to 100mm above the tray flange
- Close Cut - Method of maximising throughput and reducing film waste
- Inboard Cut (IC) option to provide 'form, fill and seal' tray presentation
- Film coding and printing
- Foil crimping
- Active conveyors to allow the machine to be used as a straight through conveyor when packs don't require sealing
- Back-to-back machine configurations
- Optional integration of peripheral equipment, such as: denesters, fillers, multi-head weighers, laser coders, labellers
- **eWON** - a machine connection system to deliver real time data and error condition support, remote setup, and software upgrades, using a customer's existing IT network
- **I-film** - intelligent film reel monitoring system which actively adjusts film tension based on reel diameter to increase print quality and film reel efficiency, reduce component duty, and provides a film end warning system
- **Protect** - a contactless machine login and audit trail system
- Sale, Lease Purchase and Rental options available

GT1e Sealing capacity

No. of trays	Length	Width	Depth	Diameter
One	300mm	670mm	120mm	270mm
Two	300mm	331mm	120mm	270mm
Three	300mm	212mm	120mm	212mm
Four	300mm	129mm	120mm	129mm
Five	300mm	98mm	120mm	98mm